

Essential Pro, guaranteed service

The leading range of juicers on the market can be programmed according to the location of use. Its new touch display gives the juicer endless possibilities, with two modes:

Self-service mode offers self-service just by pressing the new tap, with an incorporated drip-free system.

Autostart mode the juicer starts just by inserting the fruit you wish to squeeze and will stop automatically when the cycle has finished.

Zumex Essential Pro also enables you to configure many other functions – from counting the cups of juice that have been served or choosing the language of the menu, to changing the contrast of the screen or making an incident report for the technical service.

Thanks to the **wide range of accessories** available for Zumex Essential Pro, the juicer adapts better to the location. The stand designed for this juicer enables the extension of the capacity of peel waste because it is collected inside. Zumex Essential Pro is also prepared to be installed on the countertop with a device that lets the peel fall straight into a bucket under the countertop. Both accessories, **together with the standard drip-free tap** guarantee simple and hygienic work, thanks to the tray which can be easily removed, and because the size and materials are suitable for any dishwasher.

Zumex Essential Pro is **ideal for cafés, bars, restaurants...** with a low or medium demand of juice, and is available in three colours (Orange, Silver and Graphite).

Because of all its features and its simplicity, Essential Pro guarantees service adapted to any location with Zumex's original patented squeezing system.



Authorised dealer:

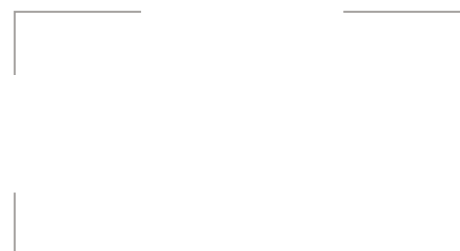

Zumex Group, S.A. Headquarters

Poligono Ind. Moncada III
C/ Molí, 2 46113 Moncada
Valencia, Spain
Tel. +34 961 301 251
Fax. +34 961 301 255
zumex@zumex.com

Zumex USA Inc. USA & Canada

1573 NW 82nd Ave,
Miami, FL 33126
USA
Tel. 1 305 591 0061
Fax. 1 305 591 0062
Technical Assistance:
1-877-ZUMEX-TA
(1 877 986 3982)
zumexusa@zumex.com

Zumex México

Uxmal 616
Colonia Vertiz Narvarte
Delegación Benito Juárez
CP 03600 México D.F.
México
Tel. (55) 5212-0619 / 5212-1171/
5212-1185 / 5212-1184
zumexmexico@zumex.com

www.zumex.com

discover
life essence



235.6187.100

ESSENTIAL PRO





TECHNOLOGICALLY PERFECT

General characteristics

- Programmable according to the location of use:
Self-Service: The juicer starts up by pressing the new tap.
Autostart: It starts automatically when you insert the oranges in the feeding tube.
- Touch Control Button Panel with an interface that shows the user the status of the machine at all times, and with a menu with many options that enable total control of the service.
- New drip-free tap system.
- Available in three colours: Orange, Silver and Graphite.
- New easily removable base, suitable for dishwashers.

Accessories

- 1 Stand**
 Available in three colours (Orange, Silver, Graphite), with an interior tray so it is easier to clean and get rid of peel.
 - 2 Bottles/cups kit**
 A system that is fixed onto the machine and dispenses cups or bottles for the consumers – ideal for self-service locations.
 - 3 Self-Service tray kit**
 Front tray to support the tray, in Self-Service locations.
 - 4 D65 squeezing kit**
 For squeezing fruit with a diameter under 65 mm.
Kit to fix on the countertop*
 To fix the machine on a countertop so that the peel falls into a bucket underneath.
Elevation kit*
 Legs that are screwed onto the machine base and raise it to clean the countertop easily.
- *Only for models without a stand

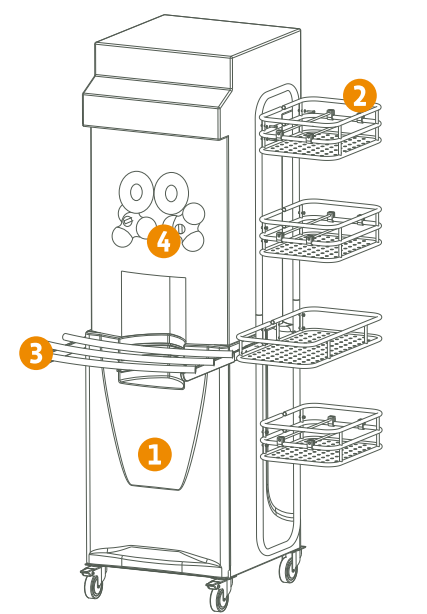

Technical Characteristics

Fruit per minute:	18 oranges/minute
Feeder capacity:	5 oranges
Fruit diameter:	Up to 81 mm
Measurements:	74x47x50 cm / 29"x 18" x 19 1/2" (with stand 154 x 47,5 x 58 cm / 60 1/2" x 18 3/4" x 23")
Net Weight:	45 kg/ 99 lb (with stand 78 kg / 172 lb)
Consumption:	0.3 kW
Voltage:	230-240 V/50-60 Hz 115V/60 Hz
Damp-proof protection:	IPX4
Safety:	Double magnetic safety detector and motor protection.

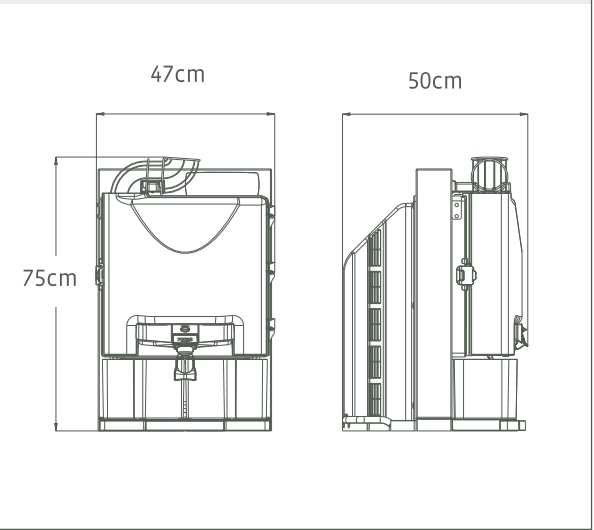

The designs and specifications of the products in this catalogue can be modified without prior notice.

Essential Pro Versions



Zumex Essential Orange



Zumex Essential Silver



Zumex Essential Graphite